

SECTION A-A

- LEGEND
- ① REQ'D 4" PLASTIC UNDERDRAIN PIPE (PERFORATED)
 - ② REQ'D AGGREGATE
 - ③ REQ'D PLASTIC FILTER CLOTH
 - ④ REQ'D 4" PLASTIC UNDERDRAIN PIPE (NON PERFORATED)
 - ⑤ REQ'D CONCRETE SLOTTED HEADWALL
 - ⑥ REQ'D SHOULDER SURFACING

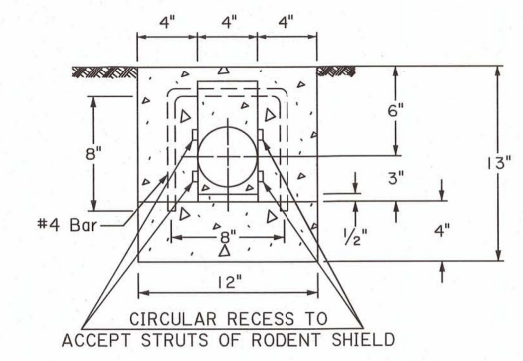

CONCRETE SLOTTED HEADWALL (FRONT VIEW)

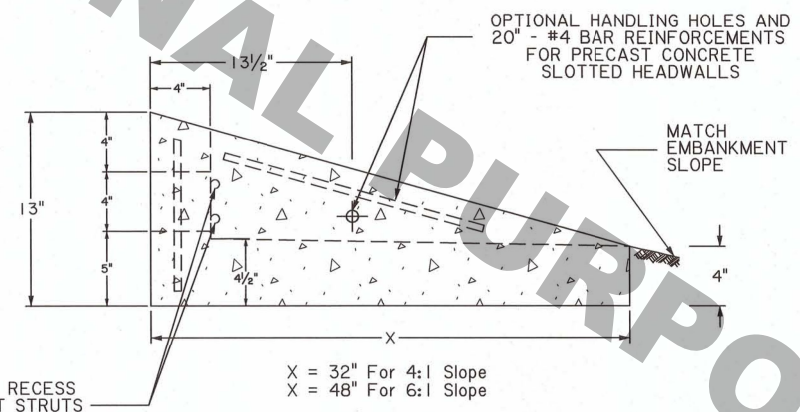

CONCRETE SLOTTED HEADWALL (SIDE VIEW)

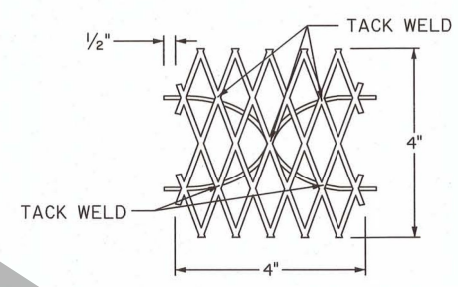

EXPANDED METAL SHIELD WITH TWO 6 GAGE STEEL WIRE STRUTS. STRUTS SHALL BE CUT FOR SNUG FIT INTO THE RECESSES IN THE CONCRETE SLOTTED HEADWALL. STRUTS SHALL NOT BE CAST IN TO THE CONCRETE

RODENT SHIELD DETAIL

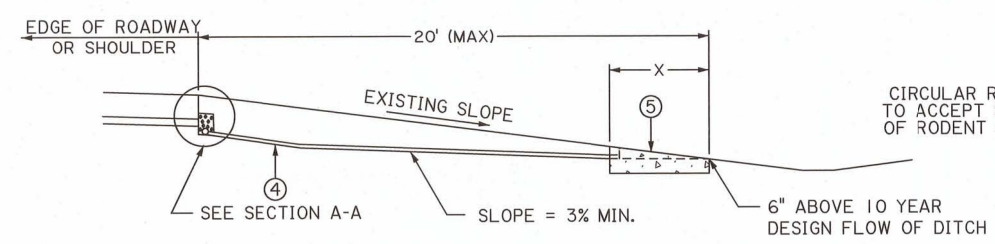

SECTION B-B

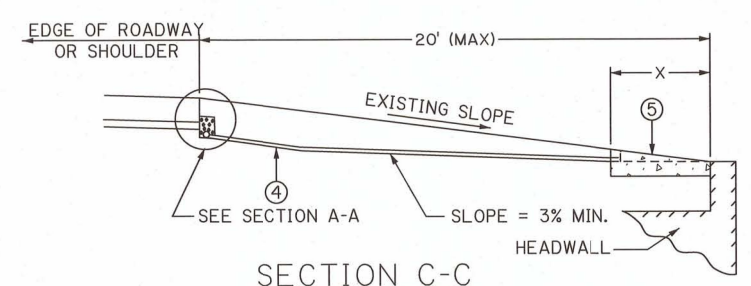

SECTION C-C

- (1) THE SHOULDER UNDERDRAIN SYSTEMS PAY ITEM SHALL INCLUDE ALL REQUIRED TRENCHING, PLASTIC UNDERDRAIN PIPE (PERFORATED), "Y" 'S, FITTINGS, PLUGS, PLASTIC FILTER CLOTH, AGGREGATE, AND BACKFILL.
- (2) THE SHOULDER OUTLET UNDERDRAINS PAY ITEM (SINGLE OR DOUBLE HEADWALL) SHALL INCLUDE ALL REQUIRED TRENCHING, PLASTIC UNDERDRAIN PIPE (NON PERFORATED), CONCRETE SLOTTED HEADWALLS, RODENT SHIELD, EXCAVATION, AND BACKFILLING WITH SUITABLE MATERIAL REMOVED FROM TRENCHES.
- (3) TRENCH DIMENSIONS SHALL BE AS REQUIRED TO PLACE UNDERDRAIN OR AS REQUIRED BY THE PROJECT ENGINEER.
- (4) FOR MORE INFORMATION ON PAVEMENT STRUCTURE REFER TO THE TYPICAL SECTIONS.
- (5) THE LAYOUT SHOWN ON THIS SHEET IS GENERAL. ACTUAL LAYOUTS SHALL BE AS DIRECTED BY THE PROJECT ENGINEER.
- (6) THERE SHALL BE NO EXCAVATION LEFT OPEN AT THE END OF EACH DAY.
- (7) THE CONCRETE SLOTTED HEADWALL CAN BE EITHER PRECAST OR CAST IN PLACE. THE UPPERMOST POINT OF THE HEADWALL SHALL BE FLUSH WITH THE ROADWAY SLOPE. THE EARTHEN SIDE SLOPES ADJACENT TO THE HEADWALL SHALL THEN BE SHAPED TO CONFORM TO THE SIDES AND TOE OF THE HEAD WALL. IF A PRECAST HEADWALL IS USED, THE UNDERDRAIN PIPE WILL BE GROUTED AND SEALED TO THE HEADWALL WITH CEMENT MORTAR.
- (8) FOR PLASTIC UNDERDRAIN PIPE SEE SECTION 1006.08 AND QPL 73.
- (9) ALL SHOULDER UNDERDRAIN OUTLET LOCATIONS SHALL BE MARKED BY PLACING A NONREFLECTORIZED RAISED PAVEMENT MARKER ON THE SHOULDER. COST TO BE INCLUDED IN THE SHOULDER OUTLET UNDERDRAINS PAY ITEM.

SHEET NUMBER		PARISH		CONTROL SECTION		STATE PROJECT	
DESIGNED	CHECKED	REVIEWED	CHECKED	SERIES NUMBER	BY	NO.	DATE
REVISION OR CHANGE ORDER DESCRIPTION							
SHOULDER UNDERDRAINS RETROFIT							
< PROJECT NAME >							